



The ASCO Model 2705 are resistive, AC load banks designed for operation indoors when up to 100 kW of resistive load is required.

LOAD BANK RATINGS

Standard capacity ratings of:

- 100 kW at 480V, 3 PH, 60Hz, 5 kW load step (Unit will provide 93.75 kW at 240V, 3 PH, 60Hz, 3.75 kW load step and will de-rate to 70 kW at 208V, 3PH, 60Hz)
- 80 kW at 400V, 3PH, 50Hz, 5 kW load step

Please consult factory for non-standard ratings.

Fan and Control Power

An external 120V, 1 Phase, 60 Hz, 5 amp power source is required for the fan and control circuits. This power is derived from the control power receptacle located on the back of the unit.

Cooling System

Proper cooling is provided by four (4) integral cooling fans. The cooling fans are fuse protected.

Operator Controls

The standard local mode is manual control via "digital toggle" switches. The local mode features full digital monitoring and individual load steps with LED indications. The integral control panel is provided for load bank operation and includes the necessary controls and status indicators.

The optional remote control mode is via the hand-held touchscreen controller. It features a 4.3" color touch screen housed in a rugged and easy to grip industrial grade enclosure. Load selection can be the sum of the entire load string (up to 25 load banks) or individual units within that string. Extremely fast and reliable CANbus communication protocol is used in the SIGMA LT for networking. CANbus protocol reduces network sag which is typically found in RS232 network load banks. A USB port is provided for data download and software updates.

Construction

The 2705 is constructed using heavy gauge aluminized steel per ASTM A463. It is designed for continuous indoor operation. Two (2) moveable and two (2) fixed casters are provided for easy mobility. Handles are provided for lifting the load bank when it is being transported. All exterior fasteners are stainless steel. The 2705 load banks are listed to UL standard 508A.

Finish

The 2705 has a high quality baked polyester powder coated finish with a film thickness of 2.8 +/- 0.4 mils per coat. The standard color is gray (ANSI 61).

Two Year Warranty Included

The equipment is covered by an industry exclusive 24-month parts and labor warranty.

Model 2705 Specifications

Resistor Elements

ASCO load banks use helically wound chromium alloy Helidyne elements. Elements are supported by ceramic insulators on internal frame supports. These elements are designed to operate at approximately 1/2 of their maximum continuous wire rating.

Elements are positioned within the cooling airstream for optimal performance. Changes in resistance due to temperature are minimized by maintaining conservative watt densities.

The overall load tolerance of the 2705 load bank is -0, +5%. This ensures that advertised kW is delivered at rated voltage.

The elements are continuously rated at the specific voltage. Tests at lower voltages, with a corresponding reduction in overall rating, may be carried out.

Safety Features

Exhaust temperature sensors are provided to monitor the flow of cooling air. These switches are electrically interlocked with the load application. If the fans are not working properly, the load steps are disabled and an error message is displayed on the load bank and also on the hand-held (if connected).

The load bank also contains fuses for short circuit protection. The control circuit is protected with a 5 amp fuse while the voltage signals to the meter are protected with 1 amp fuses. The load circuit is protected with three main line fuses (one per phase).

Ambient Temperature

The 2705 load bank is designed for continuous duty cycle with no limitations. The ambient temperatures range is -20°F to 120°F (-28°C to 50°C).

Environment

The 2705 is self-contained portable load bank designed for operation and storage indoors.

Power Terminals

Input connections are quick connect style receptacles mounted on the back of the load bank.

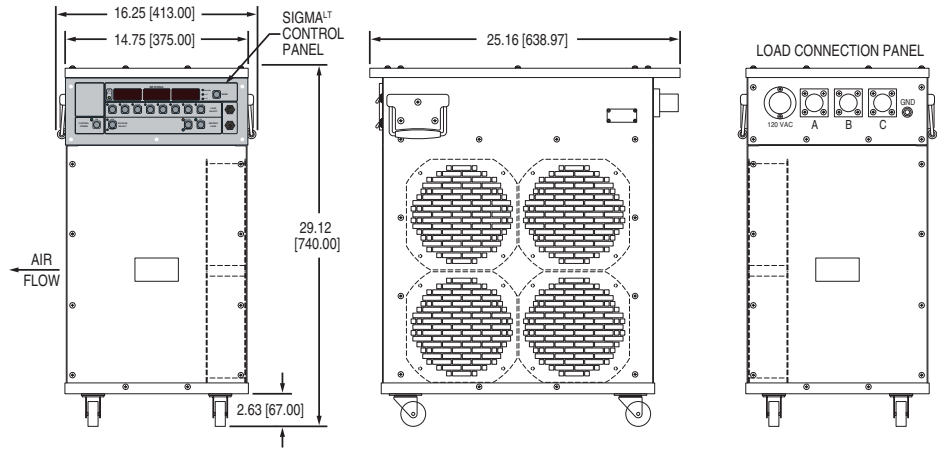

All dimensions are in inches [millimeters]. Specifications subject to change without notice.

Optional Accessories

- 4.3" Color Touchscreen Hand-Held Controller
- 5 m Interconnection Cable (other lengths available)
- Heavy Duty Transport Case
- 20' Load Cable Set with Connectors

Documentation - Operating Manual

A comprehensive operator's manual is supplied electronically via a USB drive.

Sections include: Safety, Installation, Operation, Maintenance, and Troubleshooting.

Testing and Standards

ASCO load banks comply with NEMA, NEC, and ANSI standards. Quality control system is certified to ISO9001 standards.



Optional SIGMA LT Hand-Held Terminal.

Weight and Dimensions

Dimensions (approx. in/mm)			Weight (approx. lb/kg)
Length	Width	Height	
25/639	16.25/413	29/740	105/48

Support

 SIGMA software can be updated free of charge through the ASCO website at the following link:

www.ascopower.com/firmware



Model 2705 optional heavy duty transport case.